



Mitigating the risk from the web

November 2018

About Garrison



- 4 years old
- VC backed. Raised over \$50m to date
- 50 staff operating in UK and US. Expanding into ME and SE Asia
- Building cloud hosted service alongside on-premises products
- Customers ranging from medium-sized commercial companies to large 'secure government' organisations

Would you click this link?

Who runs the
server it's
hosted on?

Who keeps the
content
updated?

Who owns this
domain?

Is the server
software
patched?

<http://www.dubiouslink.com/>

How is the server
protected?

How are the admin
credentials protected?

What other domains
does it pull in content
from?

Just another (patch) Tuesday...

CVE-2018-8475 | Windows Remote Code Execution Vulnerability

Security Vulnerability

Published: 09/11/2018

[MITRE CVE-2018-8475](#)

A remote code execution vulnerability exists when Windows does not properly handle specially crafted image files. An attacker who successfully exploited the vulnerability could execute arbitrary code.

To exploit the vulnerability, an attacker would have to convince a user to download an image file.

The update addresses the vulnerability by properly handling image files.

Security

By [Shaun Nichols](#) in [San Francisco](#) 11 Sep 2018 at 22:44

One of the more noteworthy of those bugs is [CVE-2018-8475](#), a remote code flaw that can be triggered simply by viewing an image file in Windows. While no exploits are out, Microsoft warns that details on the vulnerability are already public.

"Open the wrong image – even through a web browser – and code executes, making this a browse-and-own scenario," [explains](#) Dustin Childs of Trend Micro's Zero Day initiative.

What's to be done?

The old world

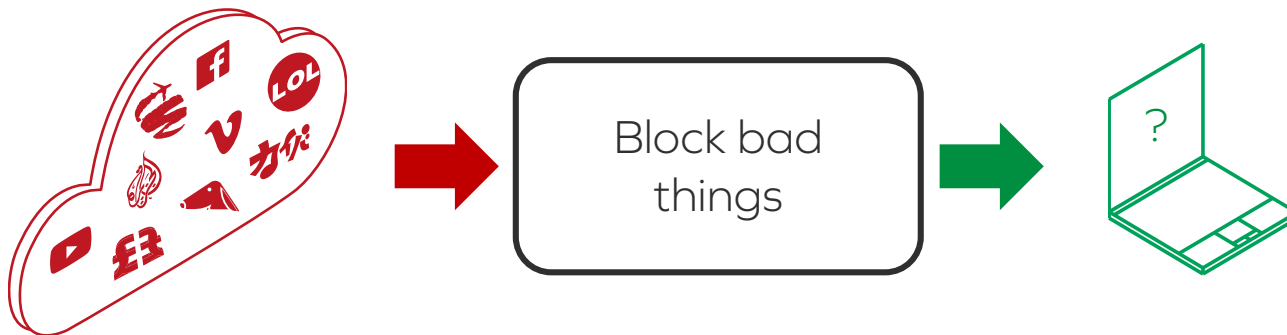

The new world



Authoritative advice

https://www.ncsc.gov.uk/guidance/pattern-safely-importing-data

 National Cyber Security Centre
a part of GCHQ

Search

Guidance | Threats | Incident Management | Marketplace | Education & Research | Insight | Press & Media | Topics ▾

Published guidance | Infographics | NCSC glossary

[Home](#) > [Guidance](#) > [Published guidance](#)

Guidance

Pattern: Safely Importing Data

Created: 16 Jul 2018
Updated: 16 Jul 2018

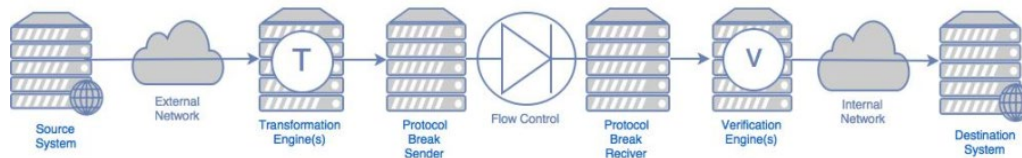

Ultra-secure browsing

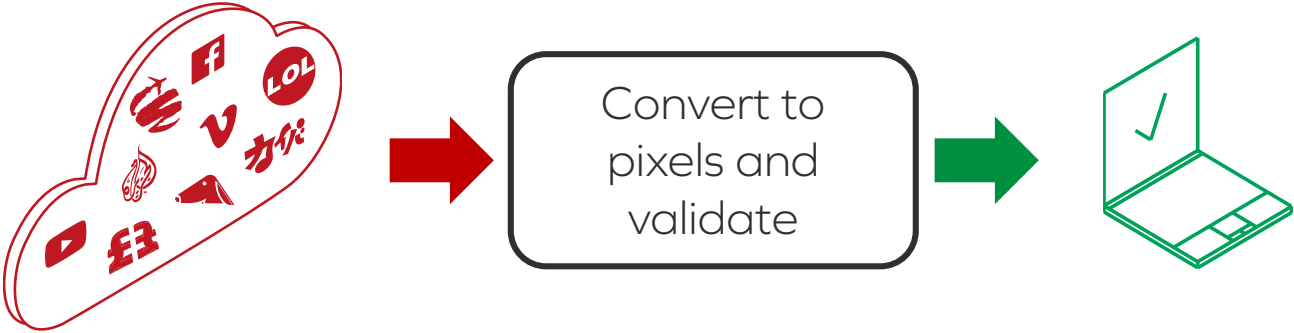

The basic concept



Robot Assured Video Isolation...



In the real world...

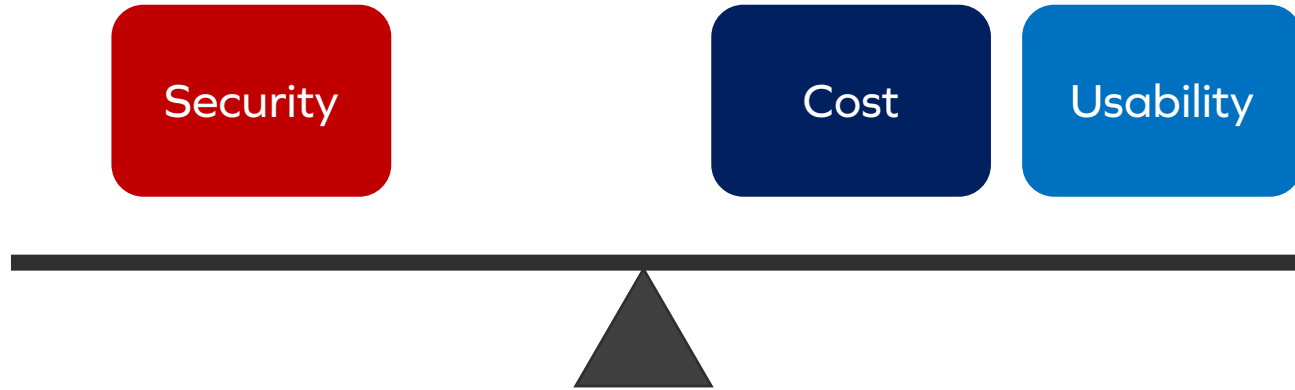

Garrison SAVI® - Silicon Assured Video Isolation

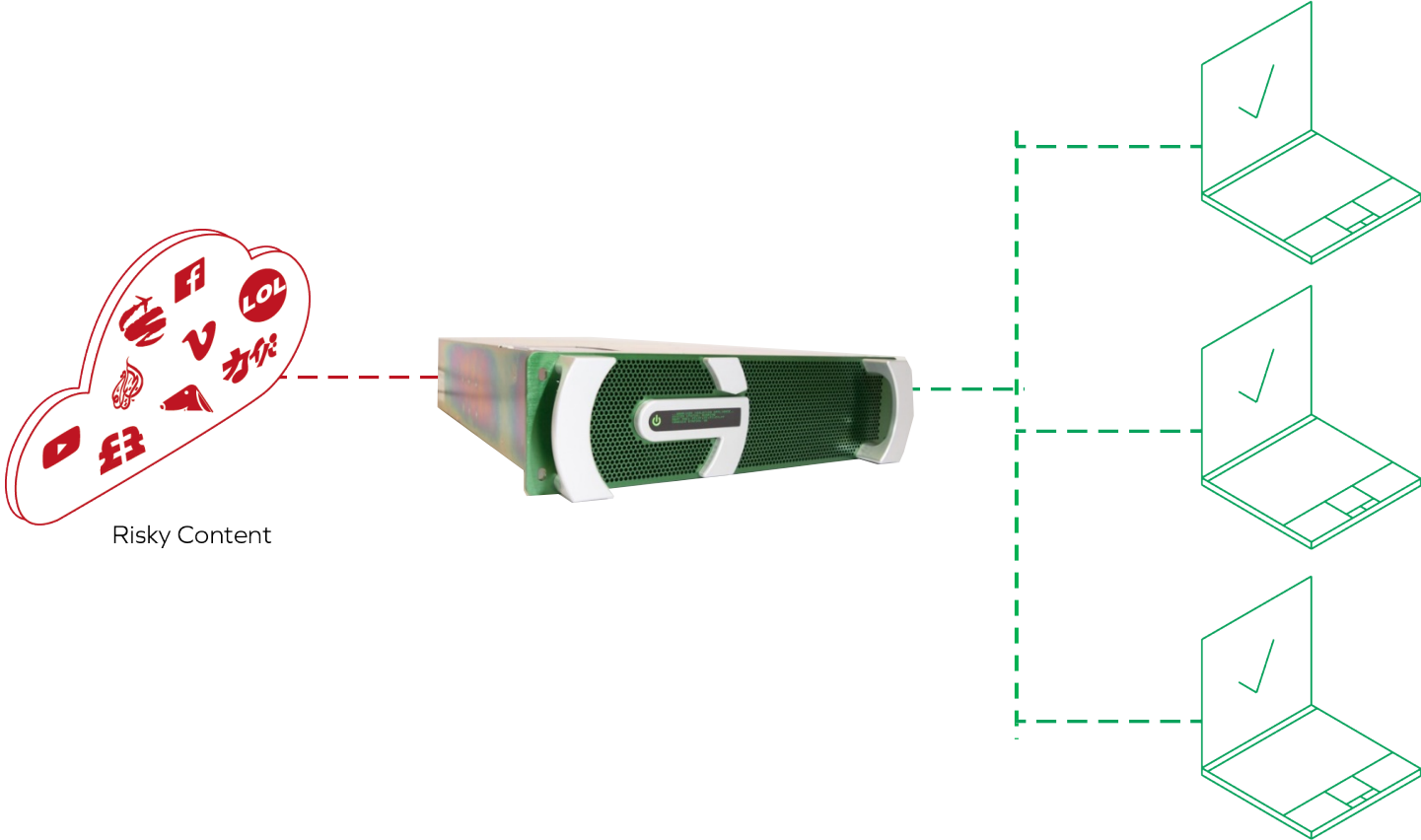

Garrison SAVI® technology

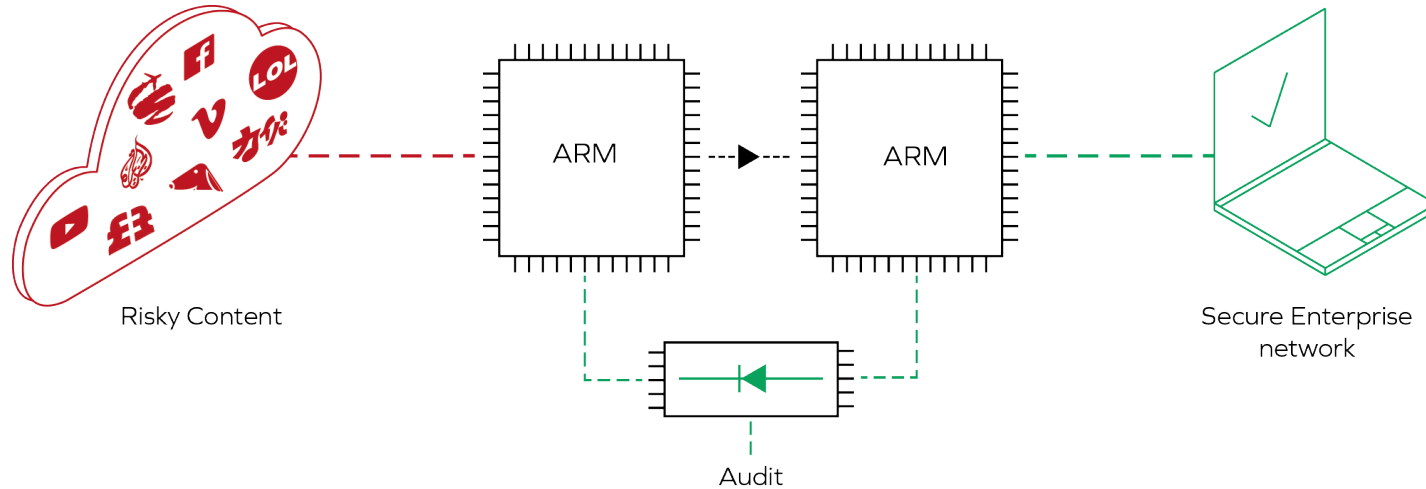



Secure Remote Browsing



Ultra-secure
internet



Guaranteed user
experience even at scale



Performance and
affordability

www.garrison.com